

IEEE 1451.0 Sensor Interoperability Experiment

Dipl.-Inf. Jesper Zedlitz

Prof. Dr.-Ing. Norbert Luttenberger

Research Group for Communication Systems

Department of Computer Science

Christian-Albrechts-University Kiel

- What is IEEE 1451?
- Why interoperability experiments?
- Experiment setup and outcome

What is IEEE 1451?

“IEEE Standard for a Smart Transducer Interface for Sensors and Actuators”

- “smart” transducer:
 - machine-readable data sheet
 - control and data digital
 - triggering, status, and control are provided
- a family of standards
- partly overlaps with OGC's standards
 - Sensor Observation Service
 - SensorML

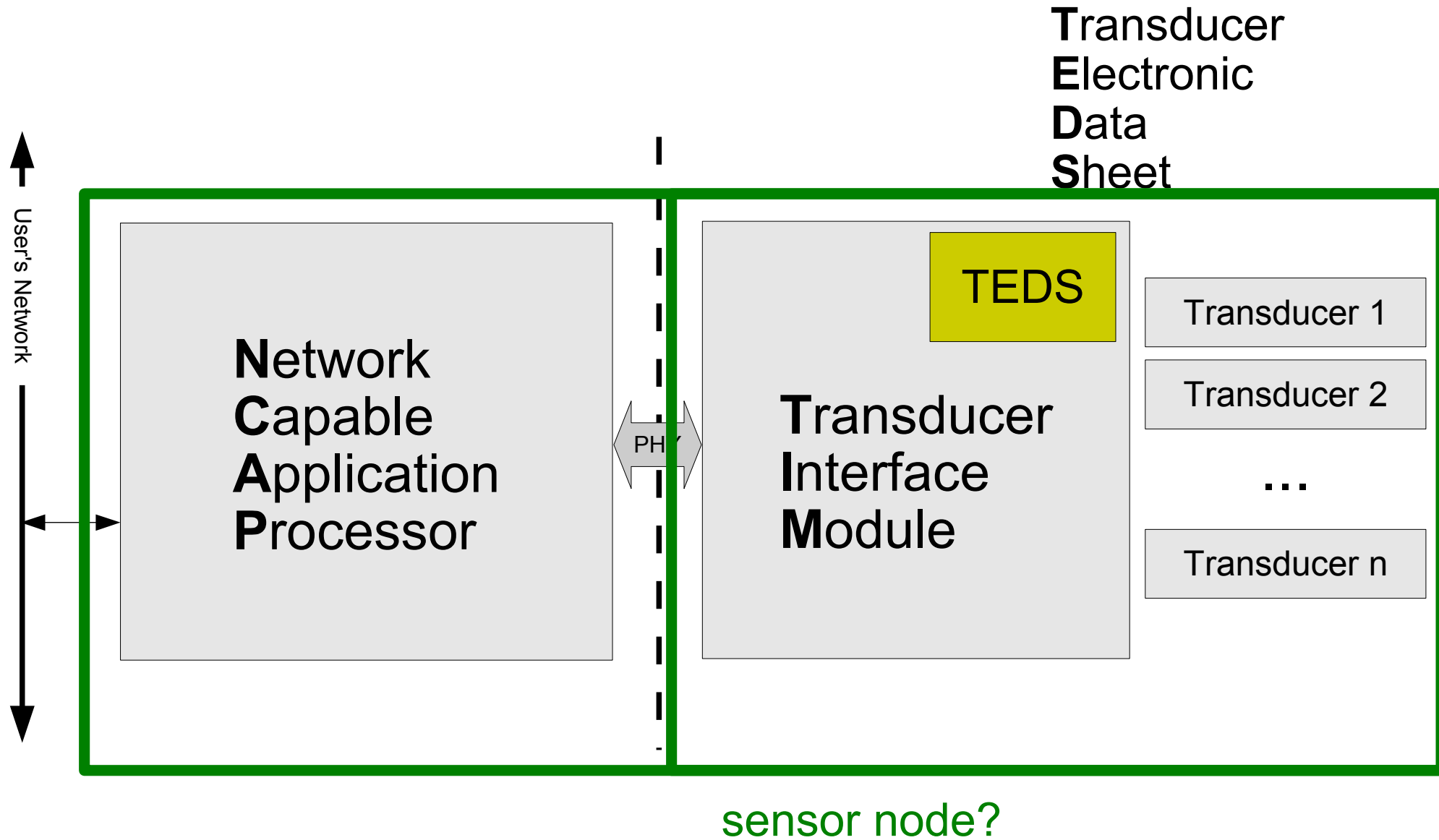

IEEE 1451 Reference Model

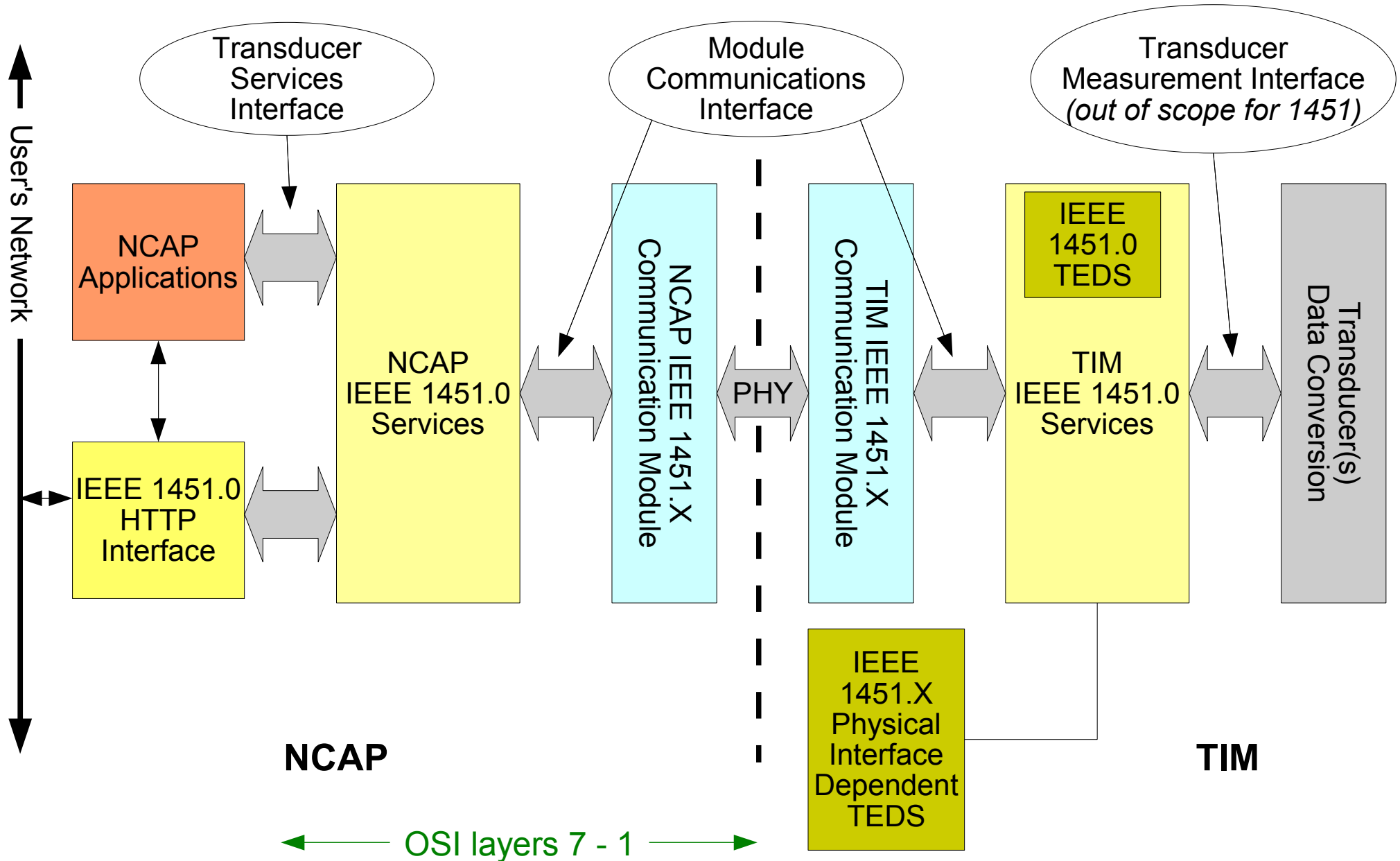

1451.X Layer

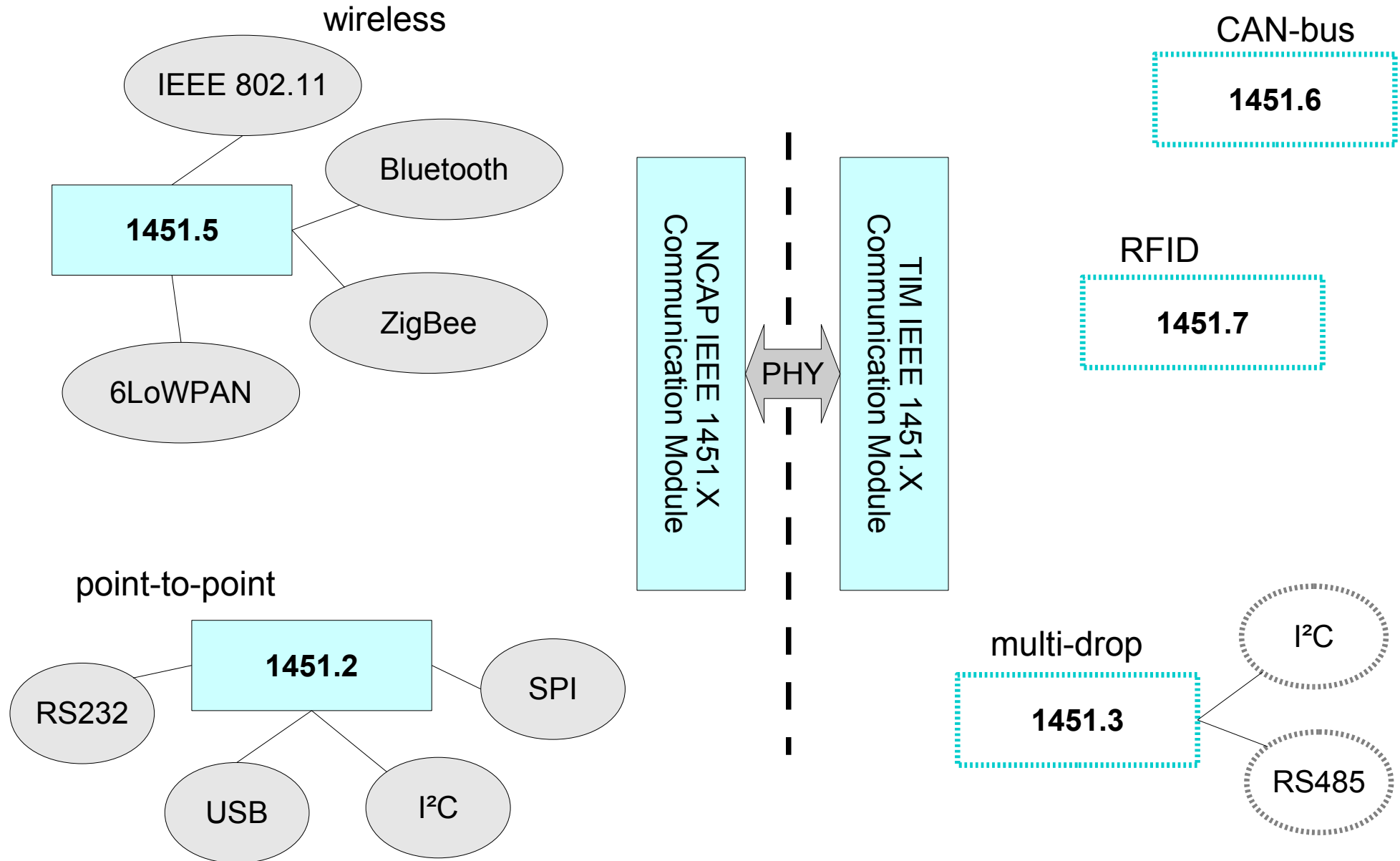

Discovery	TimDiscovery	<i>list TIMs attached to NCAP</i>
	TransducerDiscovery	<i>list transducers attached to a TIM</i>
TransducerAccess	ReadData	<i>read the current measurement value of a transducer</i>
TEDSManager	ReadTeds	<i>get electronic datasheet from a TIM or transducer</i>

Why Interoperability Experiments?

- Promising interoperability protocols
- No practical experience exists
- Complex specifications
- Ambiguities in specification
- Obstacles that hinder data exchange

Experiment Setup and Outcome

Participants

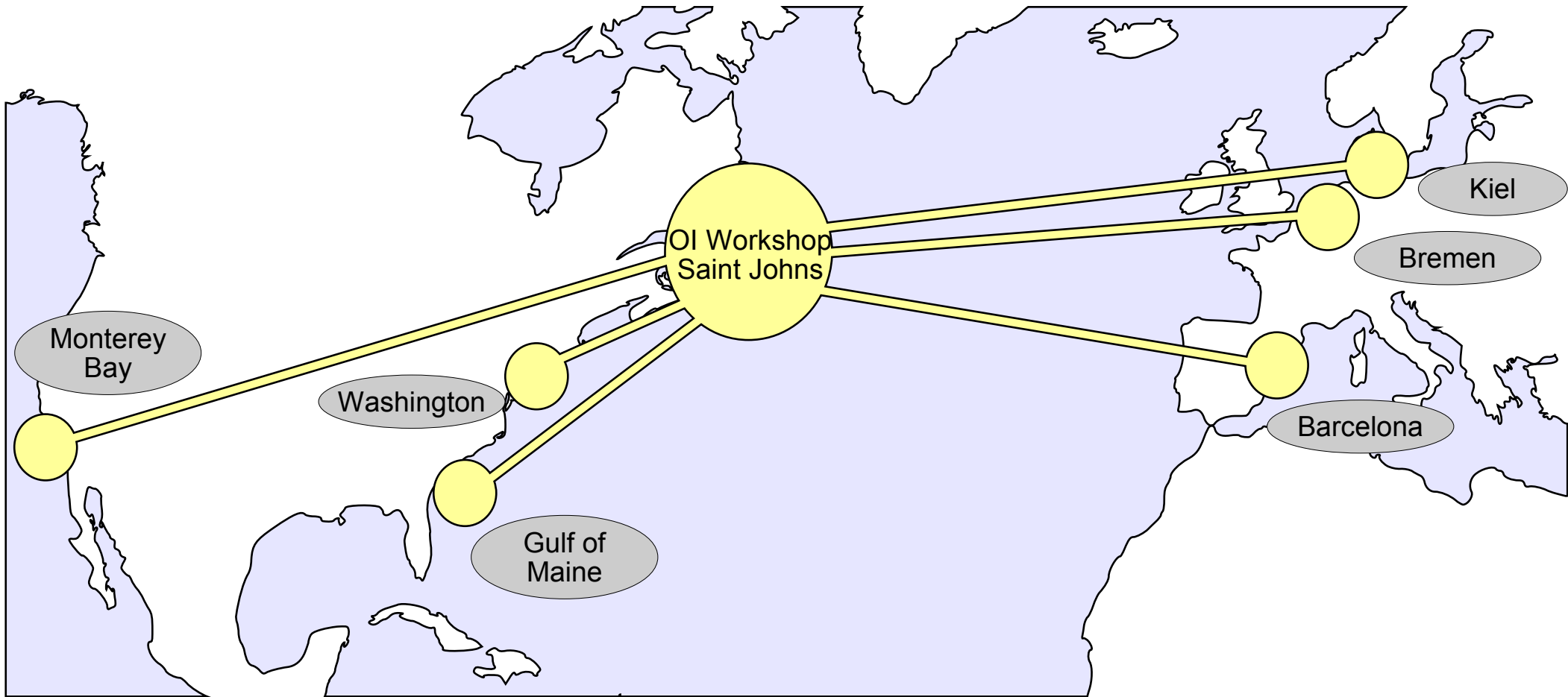

Interoperability Experiment

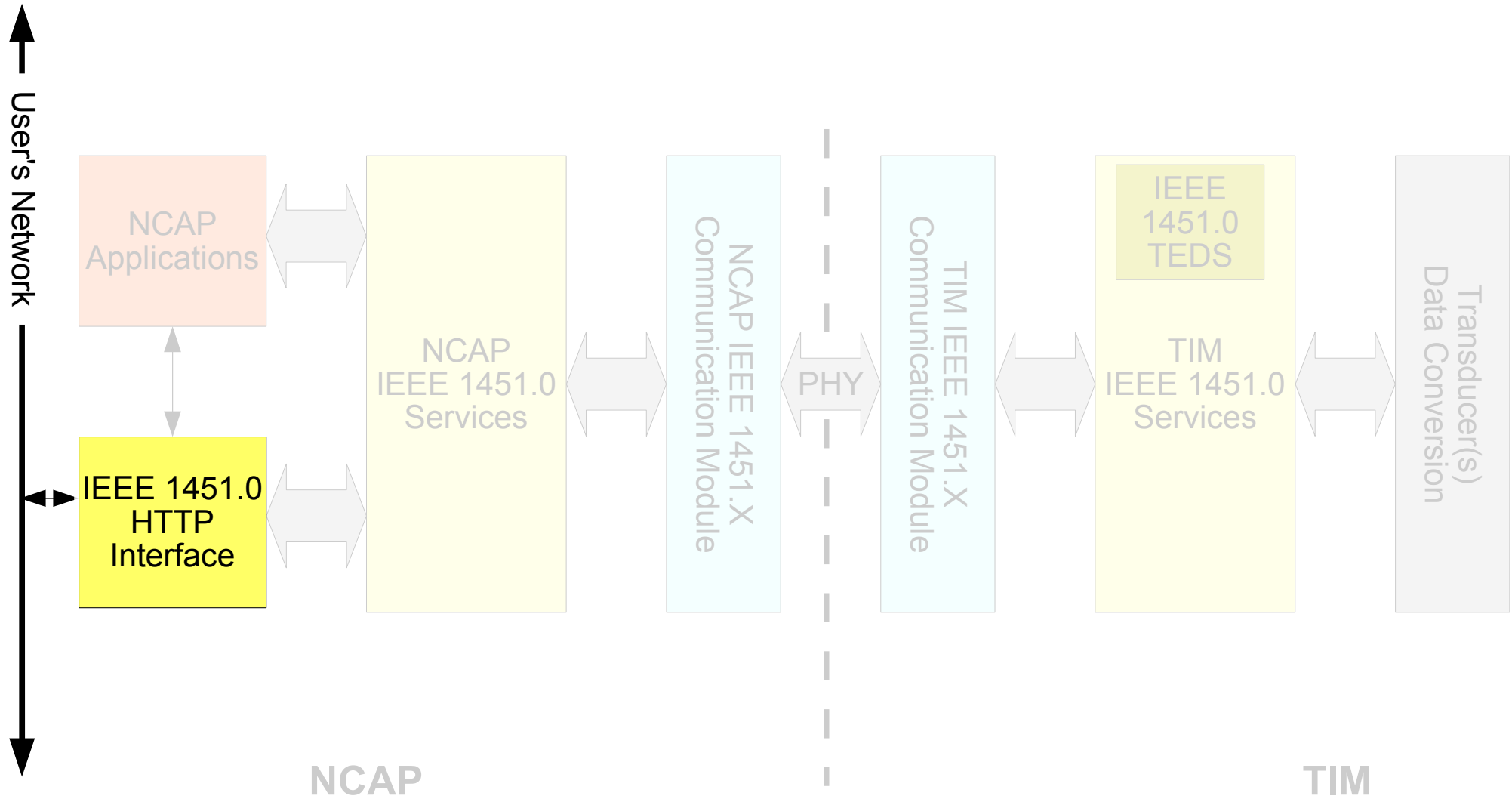

- Uses HTTP as transport protocol
- NCAP acts as server
- Requests are sent as HTTP GET requests
- Client specifies answer format: text, XML, HTML

Experiment Setup in Kiel

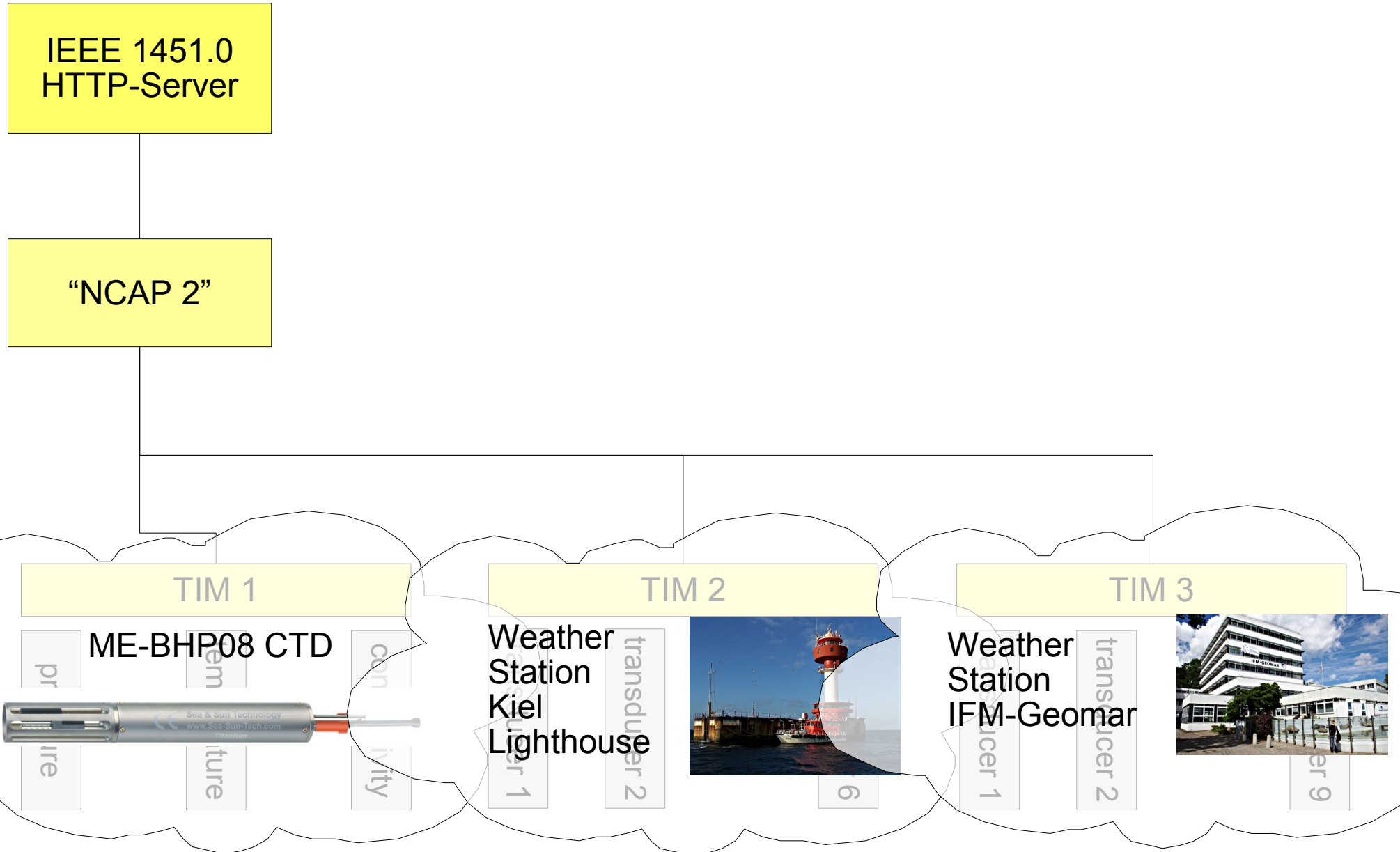

IEEE 1451.0
HTTP-Server

/1451/Discovery/TIMDiscovery?format=xml&ncapId=2

```
<SmartTransducerHTTPResponse>  
  <TIMDiscoveryHTTPResponse>  
    <errorCode>0</errorCode>  
    <timIds>1 2 3</timIds>  
  </TIMDiscoveryHTTPResponse>  
</SmartTransducerHTTPResponse>
```

“NCAP 2”

TIM 1

TIM 2

TIM 3

pressure

temperature

conductivity

transducer 1

transducer 2

⋮

transducer 6

transducer 1

transducer 2

⋮

transducer 9

Transducer Discovery

/1451/Discovery/TransducerDiscovery?ncapId=2&timId=1

IEEE 1451.0
HTTP-Server

“NCAP 2”

```
<SmartTransducerHTTPResponse>
  <TransducerDiscoveryHTTPResponse>
    <errorCode>0</errorCode>
    <timId>1</timId>
    <transducerIds>1 2 3</transducerIds>
    <transducerNames>
      pressure temperature conductivity
    </transducerNames>
  </TransducerDiscoveryHTTPResponse>
</SmartTransducerHTTPResponse>
```

TIM 1

TIM 2

TIM 3

pressure

temperature

conductivity

transducer 1

transducer 2

⋮

transducer 6

transducer 1

transducer 2

⋮

transducer 9

Read Geo TEDS

```
/1451/TEDSManager/ReadTeds?ncapId=2  
&timId=1  
&channelId=0  
&tedsType=14  
&timeoutSec=0&timeoutNsec=-1
```

```
<SmartTransducerHTTPResponse>  
  <ReadTedsHTTPReponse>  
    <errorCode>0</errorCode>  
    <timId>1</timId>  
    <transducerId>0</transducerId>  
    <tedsType>14</tedsType>  
    <teds>  
      <argument>  
        <discriminator>FLOAT32_TC</discriminator>  
        <valueFloat32>8.85041</valueFloat32>  
      </argument>  
      <argument>  
        <discriminator>FLOAT32_TC</discriminator>  
        <valueFloat32>53.1106</valueFloat32>  
      </argument>  
    </teds>  
  </ReadTedsHTTPReponse>  
</SmartTransducerHTTPResponse>
```

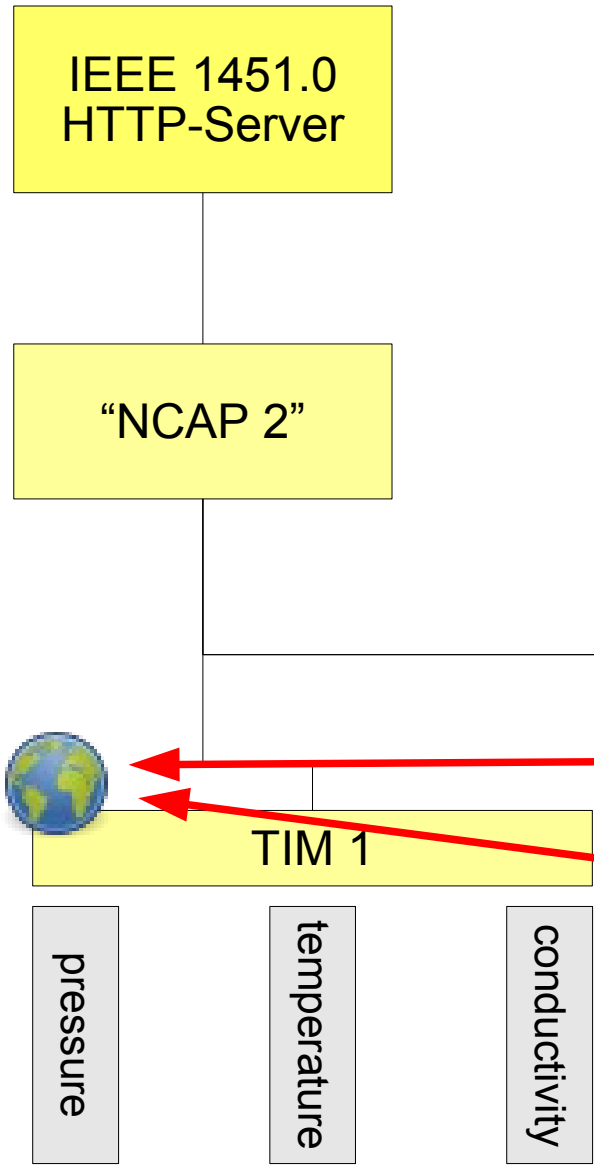

IEEE 1451.0
HTTP-Server

"NCAP 2"

TIM 1

pressure

temperature

conductivity

- IEEE 1451.0 is a complex standard
- HTTP interface needs bi-directional continuous connections
- Text format sometimes difficult to interpret
- Difficult treatment of units of measurement
- Open if/how timestamps for measurements can be transmitted

Thank you for your attention.

Reference Model

